



MA.TRA. 350



language



M A D E I N I T A L Y



MA.TRA. 350

MA.TRA.: A RANGE DESIGNED FOR GREENS MAINTENANCE PROFESSIONALS

BCS S.p.A. has been designing and manufacturing lawn mowers and garden machinery since 1943, the year of its establishment. The experience gained over the years and the success of these machines have enabled BCS S.p.A. to create a brand specifically for this market segment, namely Ma.Tra.

The professional models in the Ma.Tra. range are dedicated to users for whom a manicured garden is a true passion or a daily hobby. People and companies who use this type of machinery continuously demand the very best in terms of performance, reliability, comfort and cost-effective running, all enclosed within an innovative and attractive design.



THE NEW MA.TRA.350: DOMINATE THE CITY'S LANDSCAPE WITH A HIGHLY EFFICIENT MACHINE.

The Ma.Tra. 350 is a multi-functional greens maintenance machine with 4-wheel drive designed for the maintenance of gardens, both public and private, and for all municipal gardening work. Thanks to a complete range of professional equipments, the Ma.Tra. 350 can be used all year round. Easy handling, limited turning radius, a comfortable driving position and ultimate stability even on steep slopes and slippery surfaces ensure high performance in all conditions of use.



ENGINE WITH 44 HP POWER
and self-cleaning cooling system.

HYDROSTATIC TRANSMISSION
with a single speed range, from 0 to 20 km/h with continued variation.



TURNING RADIUS
of just 62 cm and steering wheel with hydro-guide operating on the rear wheels.



GRASS COLLECTOR WITH A REAL CAPACITY OF 1,000 LITRES and hydraulic tilting at a height of 210 cm.

AUTOMATIC DIFFERENTIAL LOCK
for maximum traction and safety.



PROFESSIONAL ATTACHMENTS
for guaranteed maximum versatility.



LARGE COMFORTABLE DRIVING POSITION
with all controls within easy reach.



PERMANENT 4-WHEEL DRIVE.

MA.TRA. 350

ENGINE AND TRANSMISSION

- > The Ma.Tra. 350 is equipped with a Yanmar 4-cylinder 2.2-litre aspirated diesel engine capable of producing 44 HP of power. The silent blocks on which it is mounted, along with the adjustment to 2,600 rpm, allow for a considerable reduction in vibrations and noise.
- > The self-cleaning screen radiator guarantees both the water and the hydraulic oil are cooled to perfection. Located in an area protected from collision and easy to inspect. A specific sensor automatically reverses the rotation of the cooling fan to clean any dust and grass cuttings from the intake grilles.
- > The transmission has a single speed range, from 0 to 20 km/h, and it ensures high performance and notable hourly output levels.

- > The four independent hydraulic motors mounted on the wheels allow the machine to operate with ease, even on steep slopes. Maximum traction and safety in all operating and grip conditions are guaranteed by the automatic differential lock that enables all four driving wheels to have grip at all times, even with the machine fully steered.
- > The PTO clutch is hydraulic multi-disc with built-in blade brake. The electro-hydraulic controlled engagement is independent from that of the intake turbine.
- > The ground clearance is 18 cm and the pivoting rear axle allow the Ma.Tra. 350 to overcome pavement curbs and bumps smoothly.

DRIVING POSITION

- > The driving position is generously-proportioned and comfortable. The professional seat is sprung and has armrests, and all the controls for lifting the attachment and the grass collector are operated by lever-operated hydraulic control valves. The steering wheel, which operates the rear wheels, is equipped with hydro-guide and it can be adjusted in height and inclination. The forward and reverse pedals are servo-assisted to reduce operator fatigue even after several hours of work.
- > The Ma.Tra. 350 is equipped as standard with folding roll-bar, seat belts and lighting system approved for road traffic. A cab with ventilation and heating or air conditioning is available as an optional.

GRASS COLLECTOR

- > The grass intake system comprises a large turbine (diameter 40 cm) that ensures maximum output even in special usage conditions with thick and wet grass. The hydraulic engagement of the turbine is independent from that of the PTO.
- > The grass collector has a real capacity of 1,000 litres. A mobile deflector situated inside it ensures it is filled evenly.
- > The hydraulic tilting at a height of 210 cm and the 50 cm rear overhang make it possible to optimise grass discharge onto the supporting vehicle container. When the grass collector is full, the lawn mower blades and the intake turbine both stop automatically.



ENGINE	Yanmar 4TNV88
FUEL	Diesel
POWER KW/HP	32,4 / 44
NOMINAL SPEED (RPM)	2.600
NO. OF CYLINDERS	4
DISPLACEMENT (CC)	2,190
COOLING	Water

- > 2.2 LITRES, 44 HP POWER AND MINIMAL VIBRATION THANKS TO THE SILENT-BLOCKS ON WHICH THE ENGINE IS MOUNTED.
- > THE FOUR HYDRAULIC MOTORS MOUNTED ON THE WHEELS ALLOW THE MACHINE TO OPERATE EVEN ON STEEP SLOPES.

- > THE SPRUNG SEAT, THE STEERING WHEEL WITH HYDRO-GUIDE AND THE SERVO-ASSISTED FORWARD AND REVERSE PEDALS REDUCE OPERATOR FATIGUE.

- > A CAB WITH VENTILATION AND HEATING OR AIR CONDITIONING IS AVAILABLE.



MA.TRA. 350

TECHNICAL FEATURES

MODEL	Multi-purpose garden machine with hydrostatic transmission
ENGINE	Yanmar 4TNV88 diesel
No. of cylinders	4
Displacement (cc)	2,190
Power (kW/HP)	32.4 / 44
Rated speed (rpm)	2,600
Cooling	Liquid with hydraulic fan and automatic radiator cleaning device
Fuel tank capacity (l)	35
Hydraulic oil tank (l)	25
Ignition	12 V electric
TRANSMISSION	Hydrostatic with 4 hydraulic motors on the 4 wheels
SPEED	From 0 to 20 km/h with continued variation
DRIVE	Permanent 4-wheel hydraulic drive
DIFFERENTIAL LOCK	Automatic and manual with push-button controls
DRIVING SYSTEM	Steering wheel with hydro-guide
PTO CLUTCH	With electro-hydraulic push-button controls and blade brake
SERVICE BRAKES	Disc, acting on the front wheels
PARKING BRAKE	Lever-operated, acting on the service brakes
SEAT	Grammer with armrests and high backrest, sprung and adjustable
STEERING WHEEL	Fitted on a steering column which is height-adjustable and can be tilted longitudinally
TURNING RADIUS (mm)	620
TYRES	With Garden profile. Front 24x12.00-12 * Rear 20x10.00-10
GRASS COLLECTOR	With electrically-controlled mobile deflector to ensure it is filled evenly. Acoustic signal with automatic blade and turbine stop when the grass collector is full
Capacity (l)	1,000
Maximum discharge height (mm)	2,100
Rear overhang (mm)	500
Intake turbine	Diameter 400 mm Operated by a hydraulic motor fitted with a safety valve against accidental collisions. Independent operation from the lawn mower
Lifting and tilting	Hydraulically controlled
Indicative hourly cutting rate (m²/h)	15,500
STANDARD EQUIPMENT	Rear tow hook, folding roll-bar, lighting system approved for road traffic, front hydraulic connection kit
OPTIONAL	Comfort cab with ventilation and heating or air conditioning

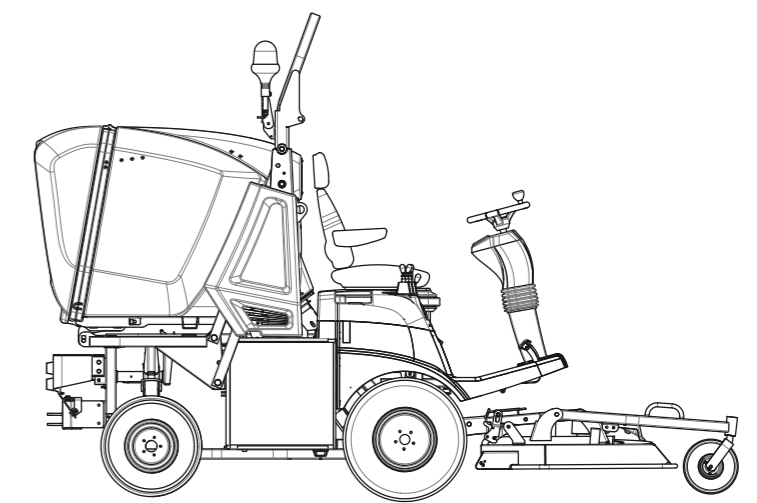
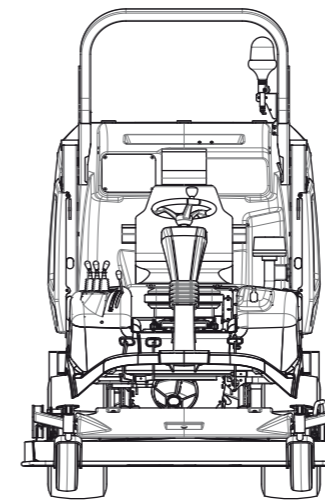

Length:	3,515 mm (with lawn mower) 2,595 mm (without lawn mower)
Width:	1,620 mm (with lawn mower) 1,350 mm (without lawn mower)
Height:	1,885 mm (with roll-bar lowered) 2,380 mm (with roll-bar raised or with cab)
Ground clearance:	180 mm
Wheelbase:	1,260 mm
Weight:	1,560 kg (with lawn mower) 1,340 kg (without lawn mower)

ATTACHMENTS



155 cm LAWN MOWER

This lawn mower with collection is built with a steel chassis and reinforced edges to avoid any wear from contact with curbs and low walls. The cutting height is adjustable to 25, 35, 50, 60, 75, 85, 95, 110 mm. The hydraulically-controlled lifting mechanism makes it possible to overcome pavement curbs and bumps smoothly. The built-in anti-scalp wheels are puncture-proof. Transmission to the blades is effected along a cardan shaft. The blades are mounted on two discs and have floating shock-resistant ends to protect the transmission from potential impact with obstacles. The blades are contra-rotating to optimise cutting and grass collection. Two adjustable springs optimise the lawn mower suspension, attenuating the ground load of the wheels with the ensuing reduction in the machine forward and reverse draft. The overturning of the mower for possible inspection, maintenance or cleaning is simple and practical and can be carried out without having to remove the cardan joint and the connecting duct to the intake turbine. The lawn mower is supplied as standard with the practical mulching kit for use with mowing without grass collection.



HEAVY-DUTY LAWN MOWER WITH 150 cm WIDE MOBILE BLADES

Designed for cutting and shredding without collecting the cuttings. The belt drive helps protect the appliance from possible impact during use. Equipped with a central rotor with 'Y' blades and a rear roller to adjust the cutting height, it is supplied as standard with a mulching bar that increases the crushing of the cuttings. It also comes with an airing kit for use to stimulate and develop turf and lawns.



175 cm WIDE SNOW BLADE

An indispensable equipment for clearing away snow in winter. Equipped with rubber ends, it is hydraulically adjustable (+/- 30°) directly from the driving position.

THE SERVICES



SPARE PARTS

A complete range of original spare parts, guaranteed directly by the manufacturer.



ASSISTANCE

A team of specialists, well prepared and available to assure an efficient and resolving service.



WARRANTY

A precise certainty for the customer's satisfaction:
2-year warranty included in the price.



LUBRICANTS

We recommend to use the original PowerLube lubricants.



BCS S.p.A.

Viale Mazzini, 161

20081 Abbiategrasso (Milano)

Tel. +39 02 94821

Fax +39 02 94960800

E-mail: info@bcs-ferrari.it

www.matragarden.it

